



**FAW**  
CAMIONES  
GRUPO BAJÍO



# FAW TIGER 5T

## 1506

Descubre nuestro camión para cargas ligeras y seguras, es un camión versátil excelente para diversas aplicaciones como caja seca o refrigerada, recolector de basura, cisterna, grúa, etc.



[www.fawbajio.com](http://www.fawbajio.com)

Tipo		FAW1506		
<b>Cabina</b>				
Ancho	(mm)	2010		
<b>Peso</b>				
GVW	(Kg)	8800		
Peso del chasis	(Kg)	2900		
Carga útil-equipo aliado	(Kg)	5900		
<b>Motor</b>				
Modelo	Cummins ISF3.8s5154			
Tipo	4 cilindros, turboalimentado e intercooler, carril común controlado electrónicamente			
Cilindro	(mm)	Φ102×115		
Desplazamiento	(cc)	3760		
Máxima potencia	KW(HP)/rpm	115(154)/2600		
Torque máx.	nm (ft-lbf)/rpm	500 (368.7)/1200~2200		
Tanque	(Litro)	150/aluminio		
<b>Transmisión</b>				
Modelo	WLY 6G55			
Tipo	MT/6			
<b>Eje trasero</b>				
Capacidad de carga	(T)	5,9		
Relación de diferencial	4,875			
<b>Neumáticos</b>				
Tipo	235/75R17.5 16PR			
Número de neumáticos	Neumático trasero doble (6+1)			
<b>Sistema de frenos</b>				
Tipo de freno/freno de estacionamiento	Tambor, freno de aire/freno de corte de aire/ABS			
<b>Suspensión</b>				
Delantero trasero	3/10+4			
<b>Tecnología</b>				
Audio	Radio con USB, 4 altavoces			
Sistema de aire acondicionado	acondicionador de aire manual			
Capacidad de la batería	Ah	12V—100Ah		
Ventanas/Puertas	Ventanas eléctricos + cierre centralizado			

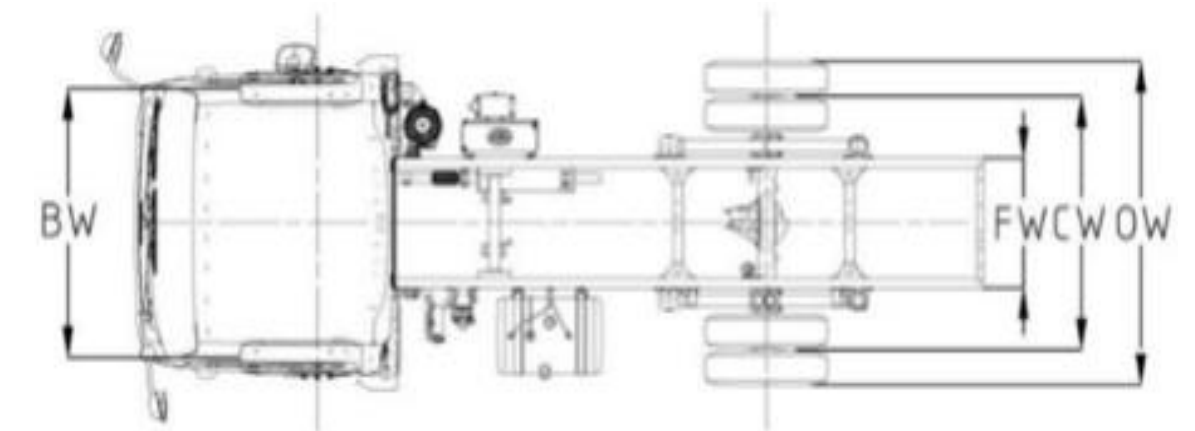
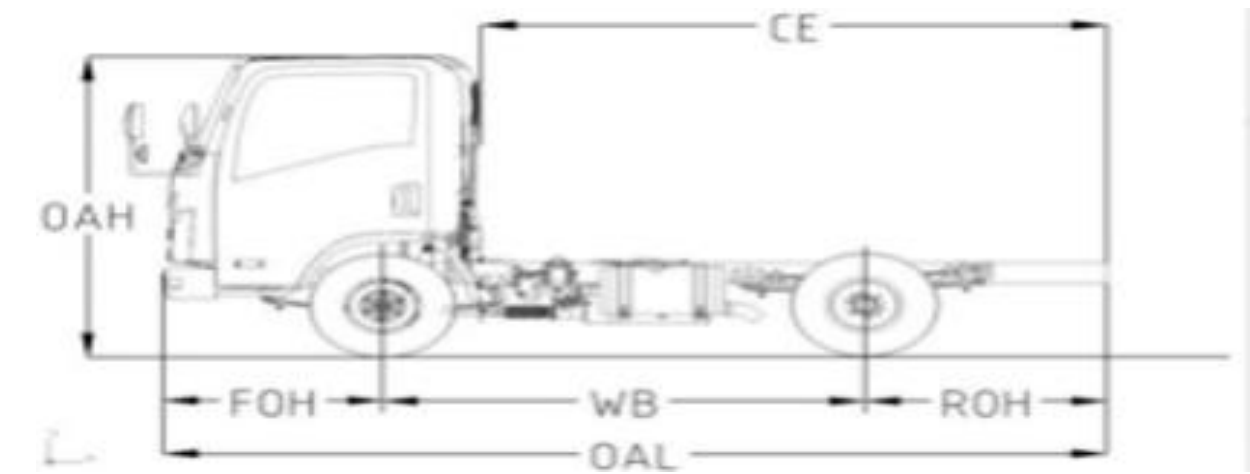

## Aplicaciones

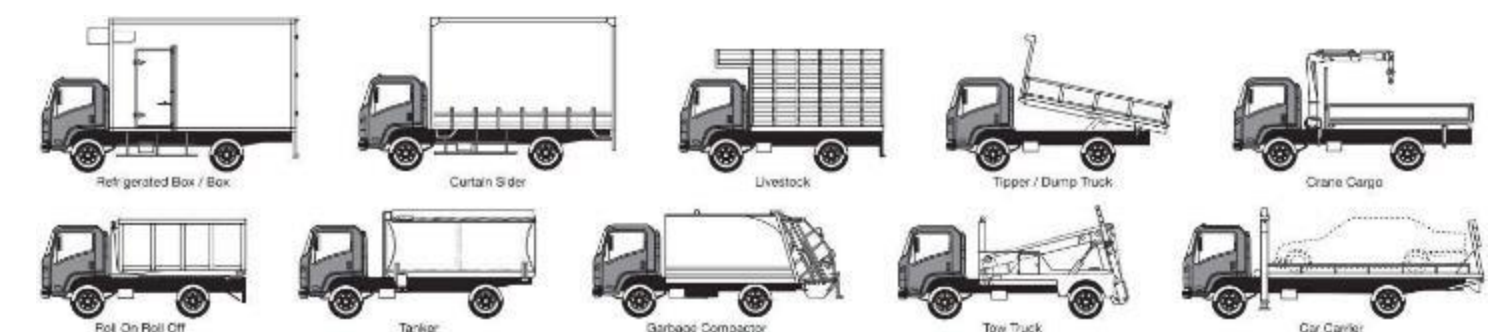

Chassis Size (mm)										
Model	OAL	OW	OAH	WB	FOH	ROH	FW	CE	BW	CW
Tiger V 5T	6835	2420	2470	3900	1115	1820	865	5200	1739	1740



# FAW Tiger 5T



[www.fawbajio.com](http://www.fawbajio.com)